



**Série - HS2 400**

# Especificações

# Especificaciones

# Features

<b>Capacidade</b> Capacidad Capacity	t	200 F5	300 F5	400 F5	500 F5
<b>Curso do martelo</b> Carrera del martillo Stroke length	mm	250	280	300	300
<b>Velocidade</b> Velocidad Speed	gpm	25 a 35	25 a 35	25 a 35	25 a 35
<b>Mesa</b> Mesa Bolster	mm	2100x1000	2300x1000	2500x1600	3000x1500
<b>Altura de trabalho</b> Altura de trabajo Working height	mm	7	7	8	8
<b>Regulagem martelo</b> Ajuste del martillo Slide adjustment	mm	120	120	120	120
<b>Distância máx. mesa x martelo</b> Distancia max. mesa y martillo Bolster to slide max. distance	mm	850	900	1300	1300
<b>Altura ferramenta fechada</b> Altura del troquel cerrado Die Height (S.D.A.U.)	mm	600	700	1000	1000
<b>Altura piso à mesa</b> Altura del piso a la mesa Floor to bolster height	mm	1180	1180	1180	1180
<b>Potência do motor</b> Potencia del motor Main motor	cv	30	40	40	50
<b>Peso aproximado</b> Peso aproximado Approximate weight	kg	29200	36170	57140	72500

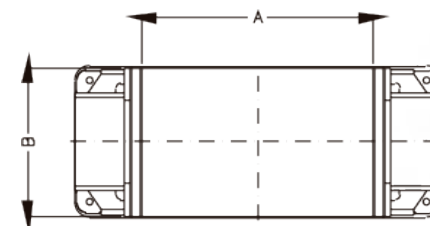
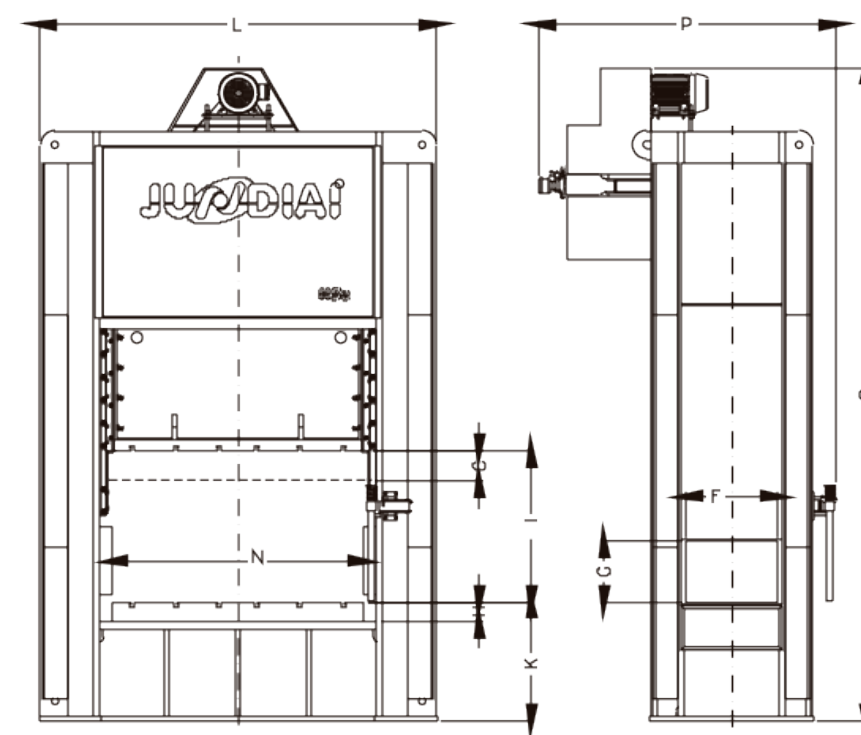

## MESA

MESA  
BOLSTER

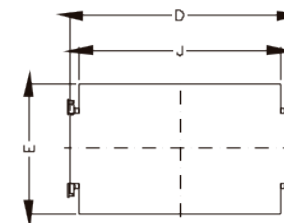

## MARTELO

MARTILLO  
SLIDE

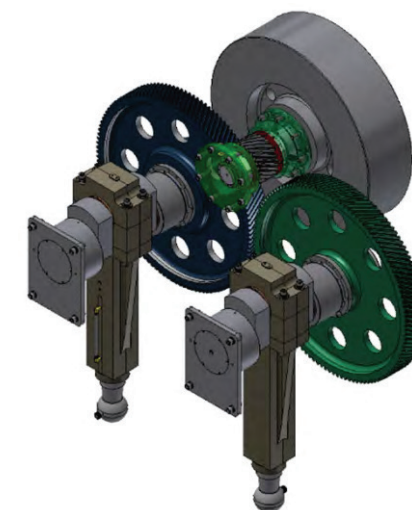

## CINEMÁTICA

CINEMÁTICA  
KINEMATICS

## Dimensões

## Dimensiones

## Dimensions

Modelo Modelo Model	A	B	C	D	E	F	G	H	I	J	K	L	N	O	P
HS2 200 F5 (mm)	2100	1000	250	2300	1000	700	400	160	850	2060	1180	3240	2120	5050	2450
HS2 300 F5 (mm)	2300	1000	280	2500	1000	700	500	190	900	2260	1180	3570	2320	5300	2450
HS2 400 F5 (mm)	2500	1000	300	2700	1000	900	615	190	1300	2460	1180	3940	2520	5850	2710
HS2 500 F5 (mm)	3000	1500	300	3200	1500	1100	615	190	1300	2960	1180	5900	3020	6130	3130

Portugues

Español

English

F5 - Curso Fixo / Engrenagem

F5 - Fixed Course / Gear

F5 - Carrera fija / Engranaje



[www.prensajundiai.com.br](http://www.prensajundiai.com.br)



[vendas@prensajundiai.com.br](mailto:vendas@prensajundiai.com.br)



55 11 4039 8200 / 4039 8235



Rod. Edgar Máximo Zamboto - Nº 5500 - Km 55 • Sítio Lagoa Branca • CEP 13231-700 • Campo Limpo Paulista • São Paulo • Brasil