



Série - LA1B

Especificações

Especificaciones

Features

Capacidade	t	100 F1	120 F5	150 F5	200 F5	200 F6	350 F5	350 F6	500 F5	600 F5	800 F5
Capacidad											
Capacity											
Curso do martelo - regulável											
Carrera del martillo - variable	mm	35	200	250	200	20 a 200	305	20 a 200	320	320	380
Stroke length											
Velocidade	gpm	80 a 150	35	35	30	50	35	40	30	30	30
Velocidad											
Speed											
Mesa	mm	650x800	650x800	900x950	980x900	1100x900	1200x1000	1200x1000	1100x1320	1000x1320	1000x1320
Mesa											
Bolster											
Altura de trabalho	mm	2,5	6,5	6,5	10	6,5	10	6,5	10	10	10
Altura de trabajo											
Working height											
Regulagem martelo	mm	100	100	120	120	120	120	120	120	Cunha	Cunha
Ajuste del martillo											
Slide adjustment											
Distância max. mesa x martelo	mm	550	440	1050	760	760	955	850	1000	1280	1400
Distancia max. mesa y martillo											
Bolster to slide max. distance											
Altura ferramenta fechada	mm	515	240	800	560	560	650	650	680	960	1020
Altura del troquel cerrado											
Die Height (S.D.A.U.)											
Altura piso à mesa	mm	740	900	780	920	910	950	950	1000	1360	1360
Altura del piso a la mesa											
Floor to bolster height											
Potência do motor	cv	20	15	20	25	30	40	40	40	50	60
Potencia del motor											
Main motor											
Peso aproximado	kg	6600	8300	9800	18700	22000	31500	27100	43000	52000	74000
Peso aproximado											
Approximate weight											

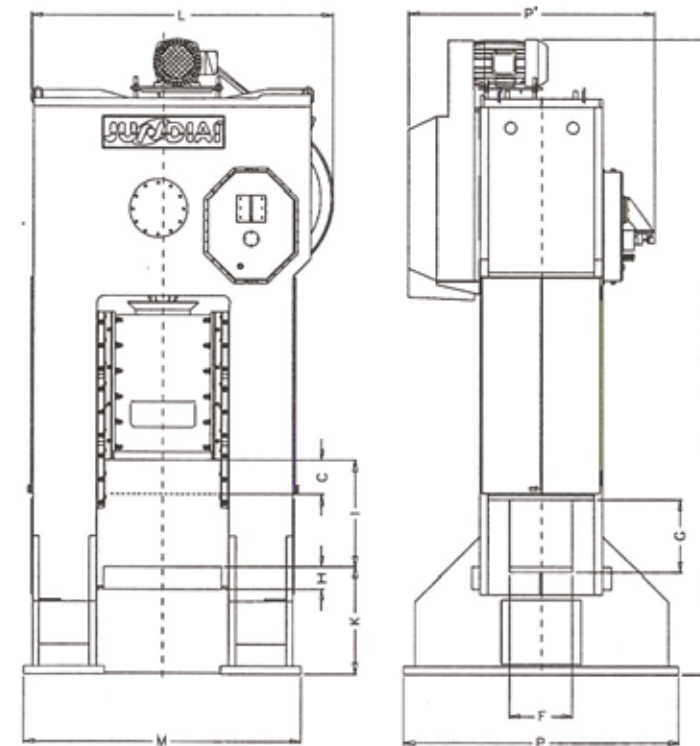

Dimensões

Dimensiones

Dimensions

Modelo Modelo Model	A	B	C	D	D'	E	F	G	H	I	K	L	M	O	P	P'
LA1B 100 F1 (mm)	800	650	35	750	510	680	420	435	125	550	740	1350	1510	3585	1150	1550
LA1B 120 F5 (mm)	800	650	200	640	390	680	350	350	125	440	900	1680	1400	3750	1150	1630
LA1B 150 F5 (mm)	950	900	250	950	710	650	330	360	150	1050	780	2300	2050	4710	1500	2050
LA1B 200 F5 (mm)	900	980	200	950	710	740	330	450	125	760	920	2300	1750	4740	1650	1915
LA1B 200 F6 (mm)	900	1100	20 a 200	1170	930	900	620	450	200	760	910	2250	1970	4400	1500	2270
LA1B 350 F5 (mm)	1000	1200	305	1170	924	1000	500	460	200	955	950	3360	2350	5340	1850	3230
LA1B 350 F6 (mm)	1000	1200	20 a 200	1170	930	850	500	460	200	850	950	2300	2100	4970	1850	2680
LA1B 500 F5 (mm)	1320	1100	320	1210	960	1150	600	640	200	1000	1000	2850	2600	6110	2600	3000
LA1B 600 F5 (mm)	1320	1200	320	1160	920	1200	600	640	260	1280	1360	2880	2700	6900	2345	2720
LA1B 800 F5 (mm)	1320	1200	380	1160	920	1200	600	640	260	1400	1360	2820	2700	7430	2400	3400

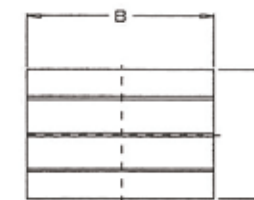

MESA

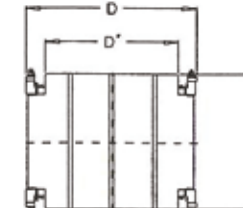
MESA
BOLSTER

MARTELO

MARTELO
MARTILLO
SLIDE

CINEMÁTICA

CINEMÁTICA
KINEMATICS

Portugues

Español

English

F1 - Volante com correia

F1 - Volanta con la correa

F1 - Steering wheel with belt

F5 - Curso Fixo / Engrenagem

F5 - Carrera fija / Engranaje

F5 - Fixed Course / Gear

F6 - Engrenagem e mesa fixa

F6 - Accionamento engronado y mesa fija

F6 - Gear and fixed bolster



www.prensajundiai.com



vendas@prensajundiai.com



55 11 4039 8200 / 4039 8235



Rod. Edgar Máximo Zamboto - Nº 5500 - Km 55 • Sítio Lagoa Branca • CEP 13231-700 • Campo Limpo Paulista • São Paulo • Brasil