



Série - LAS

Especificações

Especificaciones

Features

Capacidade						
Capacidad	†	45 F1	85 F1 4C	100 F6	160 F1 4C	300 F1 4C
Capacity						
Curso do martelo - regulável						
Carrera del martillo - variable	mm	50	50	20 a 130	50	35
Stroke length						
Velocidade						
Velocidad	gpm	100 a 300	100 a 300	40 a 70	100 a 300	100 a 250
Speed						
Mesa						
Mesa	mm	700x640	740x410	1000x800	900x800	1100x900
Bolster						
Altura de trabalho						
Altura de trabajo	mm	1,5	2	5	2	9
Working height						
Regulagem martelo						
Ajuste del martillo	mm	60	80	100	100	100
Slide adjustment						
Distância máx. mesa x martelo						
Distancia max. mesa y martillo	mm	490	550	550	610	595
Bolster to slide max. distance						
Altura ferramenta fechada						
Altura del troquel cerrado	mm	440	500	420	560	560
Die Height (S.D.A.U.)						
Altura piso à mesa						
Altura del piso a la mesa	mm	850	850	850	950	1050
Floor to bolster height						
Potência do motor						
Potencia del motor	cv	12,5	20	20	60	100
Main motor						
Peso aproximado						
Peso aproximado	kg	5400	10500	-	13700	-
Approximate weight						

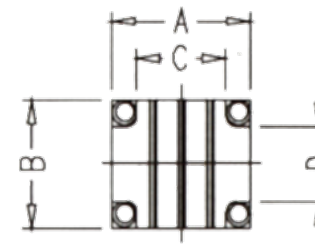
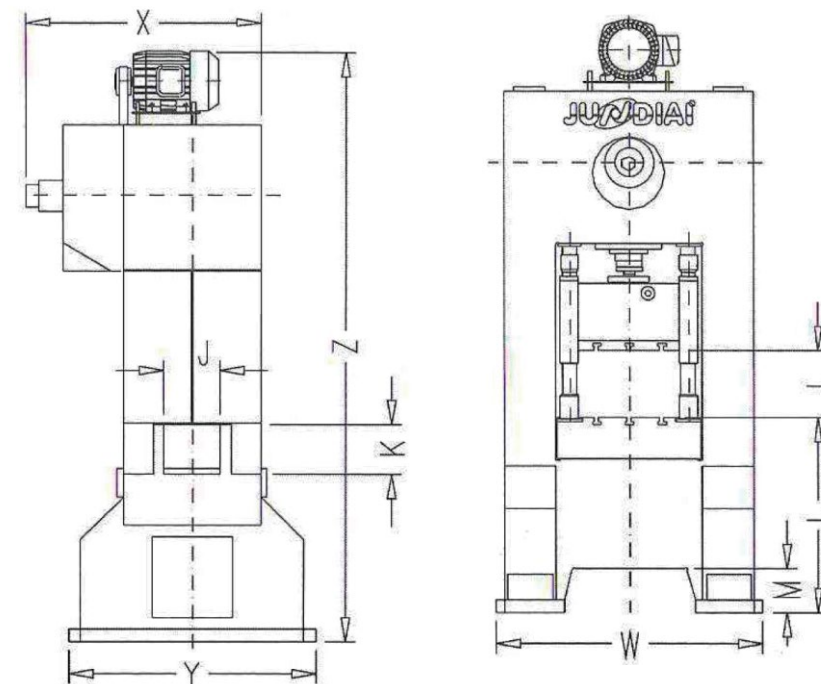

MESA
MESA
BOLSTER

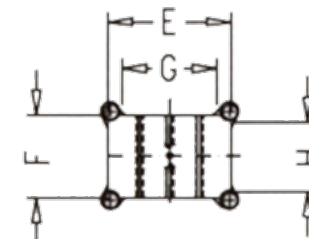

MARTELO
MARTILLO
SLIDE

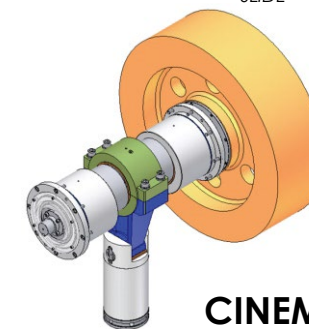

CINEMÁTICA
CINEMÁTICA
KINEMATICS

Dimensões

Dimensiones

Dimensions

Modelo Modelo Model	A	B	C	D	E	F	G	H	I	J	K	L	M	W	X	Y	Z
LAS 45 F1 (mm)	700	640	-	-	840	600	600	600	490	290	350	850	110	1540	1510	1220	3450
LAS 85 F1 4C (mm)	1000	800	740	420	960	680	750	430	550	330	400	850	200	1700	1650	1310	3900
LAS 100 F6 (mm)	1000	800	-	-	1010	680	870	680	550	330	400	850	200	1700	-	1310	-
LAS 160 F1 4C (mm)	1060	800	770	440	1000	700	750	450	610	330	400	950	170	1810	1930	1390	4330

Portugues

Español

English

F1 - Volante com correia

F1 - Volanta con la correa

F1 - Steering wheel with belt

F6 - Engrenagem e mesa fixa

F6 - Accionamento engronado y mesa fija

F6 - Gear and fixed bolster



www.prensajundiai.com.br



vendas@prensajundiai.com.br



55 11 4039 8200 / 4039 8235



Rod. Edgar Máximo Zamboto - Nº 5500 - Km 55 • Sítio Lagoa Branca • CEP 13231-700 • Campo Limpo Paulista • São Paulo • Brasil