



Série - O4C

Especificações

Especificaciones

Features

Capacidade		40	63	80	100	125	160	200
Capacidad	†							
Capacity								
Curso do martelo		300	300	400	400	500	500	600
Carrera del martillo	mm							
Stroke length								
Velocidade		150-26-205	150-23-226	150-19-216	150-19-243	150-17-240	150-17-184	150-15-191
Velocidad	gpm							
Speed								
Mesa		600 x 600	600 x 600	800 x 800	800 x 800	1000 x 1000	1000 x 1000	1200 x 1200
Mesa	mm							
Bolster								
Altura ferramenta fechada		200	200	250	250	300	300	350
Altura del troquel cerrado	mm							
Die height (S.D.A.U.)								

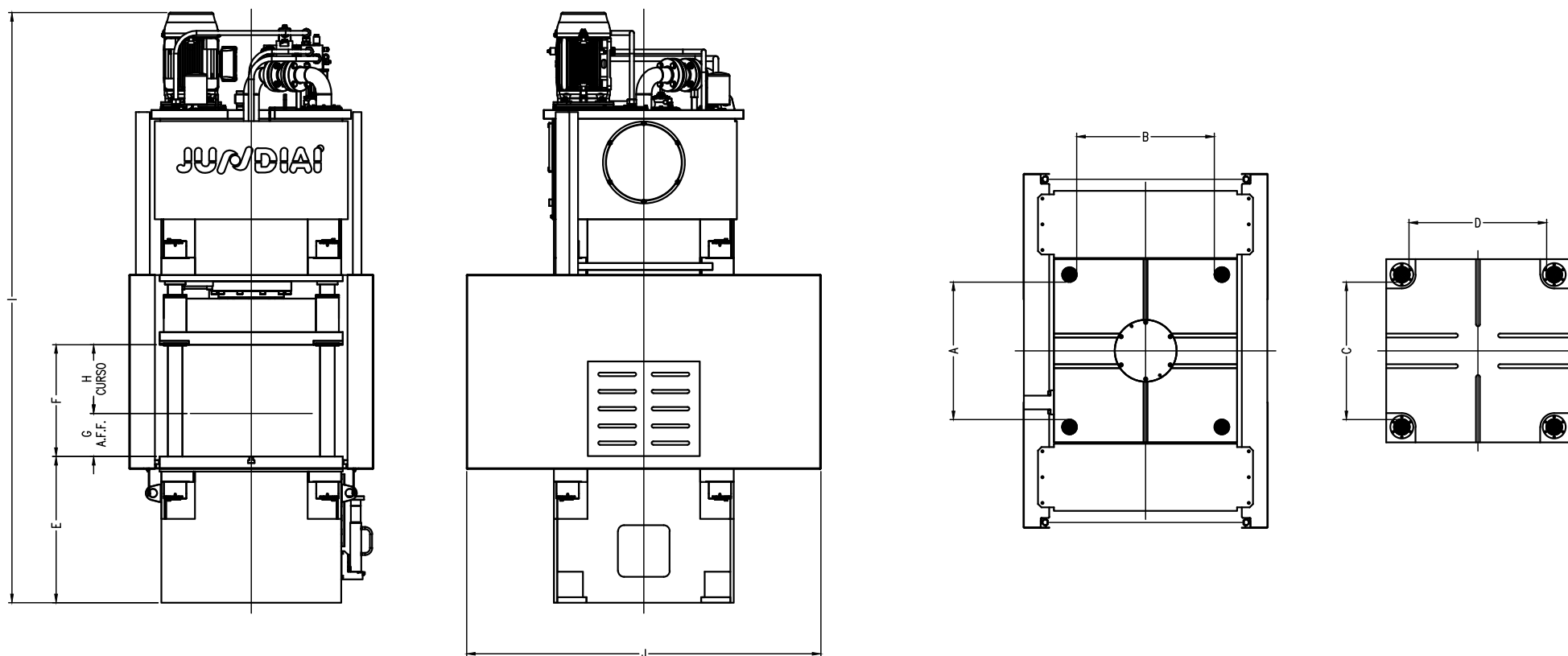

www.prensajundiai.com.br



vendas@prensajundiai.com.br



55 11 4039 8200 / 4039 8235



Rod. Edgar Máximo Zamboto - Nº 5500 - Km 55 • Sítio Lagoa Branca • CEP 13231-700 • Campo Limpo Paulista • São Paulo • Brasil